

SALES DRAWING SALES DRAWING

SALES DRAWING SALES DRAWING

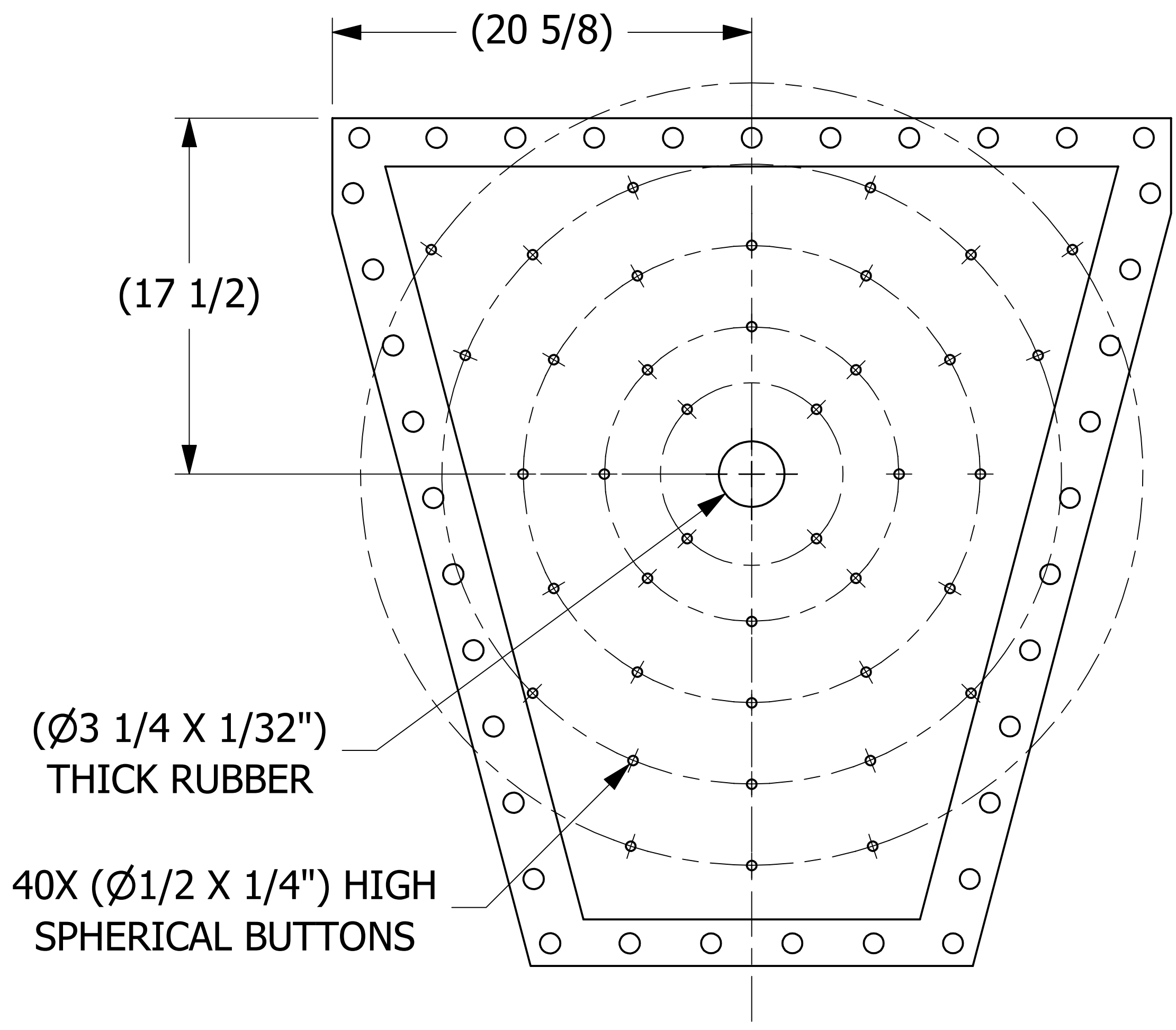
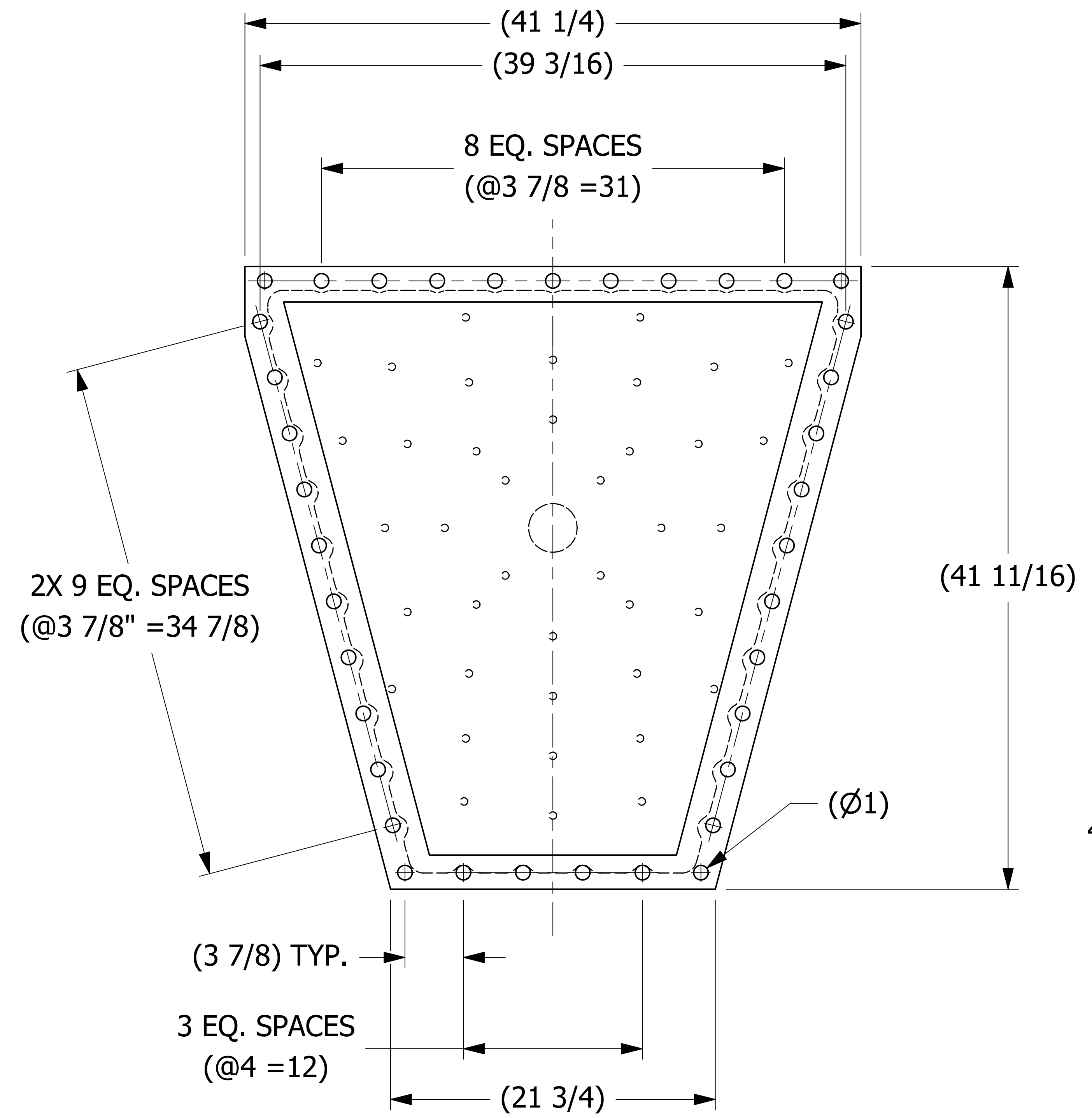

- NOTES:**
1. MATERIAL SPEC. FOR FABRIC: FDA 3 PLY SOLID WOVEN COTTON 5/32" THICK.
  2. MATERIAL SPEC FOR GASKET: TAN FDA SBR RUBBER DURO 75±5.
  3. GASKET THICKNESS IS .125 ON EACH SIDE. OVERALL THICKNESS OF OF PART INCLUDING FABRIC AND GASKET IS .41 ± .03.

B	BG	3-4-13	CHANGED BOLT HOLES TO Ø1" AND UPDATED DRAWING TO CURRENT STANDARDS
A	FOD	1-10-00	CHANGED BOLT HOLES WERE Ø0.56
REV	BY	DATE	DESCRIPTION

<small>UNLESS OTHERWISE SPECIFIED DIMENSIONAL TOLERANCES</small> FRACTIONAL: ±1/16 X.XX: ±.03 X.XXX: ±.015 ANGULAR: ±1° <small>DEBURR ALL SHARP EDGES. ALL MACHINED SURFACES TO HAVE A 125 RMS FINISH UNLESS NOTED OTHERWISE.</small> <small>THIRD ANGLE PROJECTION</small>	DRAWN BY:	SAB
	CHECKED BY:	KRSA
	PROTOTYPE BY:	SAB
	PROTOTYPE DATE:	3/4/2013
	APPROVED FOR PRODUCTION BY:	KRSA
	PRODUCTION DATE:	10/20/1998

<b>SALCO PRODUCTS, INC.</b>		
<b>PDII AERATOR PAD</b>		
<b>SEE NOTES 3 &amp; 4</b>		
PROJECT #:	980426	SHEET #:
		1 OF 1
SCALE:	1:5	
DRAWING #:	D9723	PART #:
		PD2AP3C23

THIS PRINT, PROPERTY OF SALCO PRODUCTS INC. CONTAINS PROPRIETARY INFORMATION AND MUST NOT BE COPIED, REPRODUCED, OR USED DETRIMENTALLY TO OUR INTEREST.